



**Precast Concrete & Accessories**

58 Prospect Street, Auburn, N.Y. 13021

315 252 7214 1 800 479 6335

Fax 315 252 7859

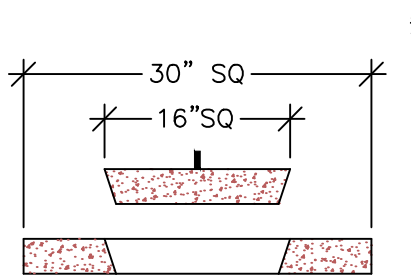

OPTIONAL COVER  
NOT FOR H-20 APPLICATIONS

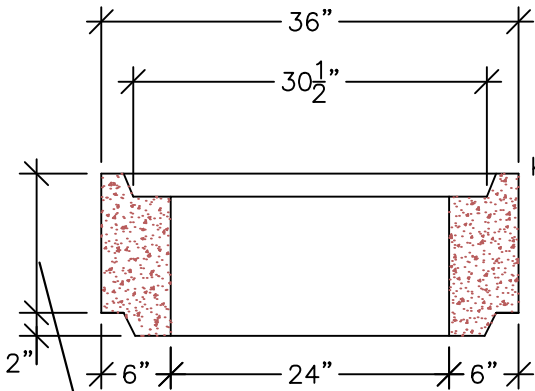

RISER HEIGHTS VARY  
FROM 6", 12", 24", 36", 48"

RISER (OPTIONAL)

SPECIFICATIONS:

MEETS OR EXCEEDS 5000 PSI CONCRETE 54"  
(MEETS ASTM 890)

AIR ENTRAINMENT 6%

STEEL MEETS ASTM A615 GRADE 60

H-20 LOADING

WEIGHT:

- 2457 LBS. [1.2 TON]
- RISER—PER FOOT OF RISE: 740 LBS. [.37 TON]

GALLONS:

- 2.49 GALS PER INCH OF RISE

#4 REBAR ONE TOP  
ONE BOTTOM ONE  
IN EACH CORNER

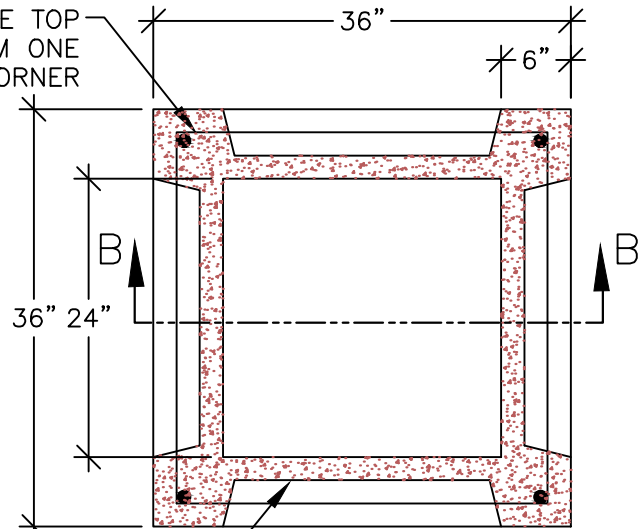

SECTION A-A

KNOCK OUT (TYP x 4)

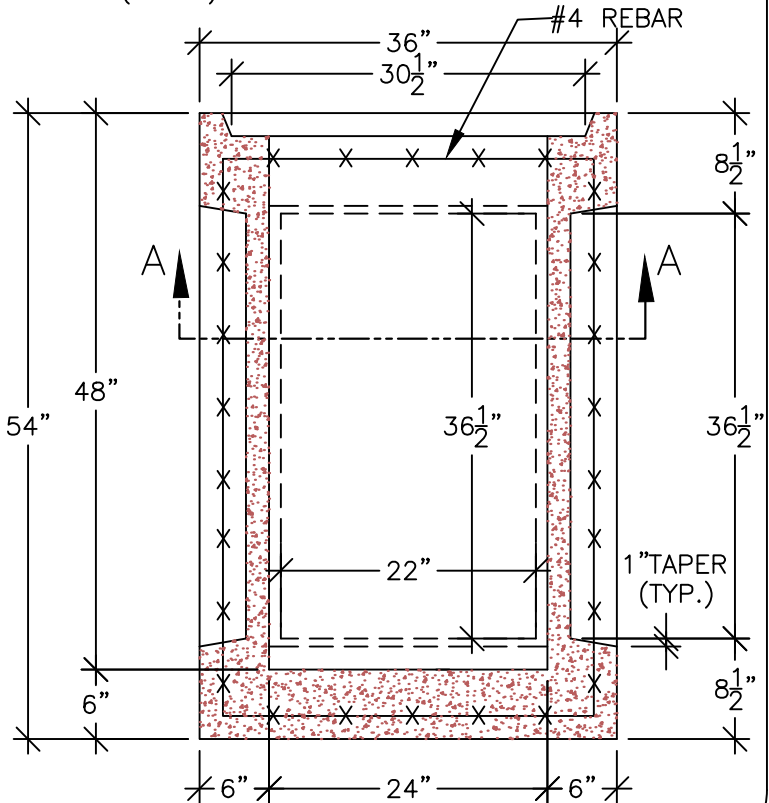

SECTION B-B

**CATCH BASIN 24" X 24" X 48" WITH KNOCKOUTS**

DRAWN BY: LWK

FILE NAME:  
CB-2448KO

DATE:  
10/15/02

SCALE:  
3/4"=1'-0"

SHEET:  
CB-5