



Precast Concrete & Accessories

58 Prospect Street, Auburn, N.Y. 13021

315 252 7214 1 800 479 6335

Fax 315 252 7859

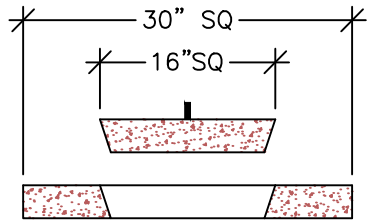

OPTIONAL COVER
NOT FOR H-20 APPLICATIONS

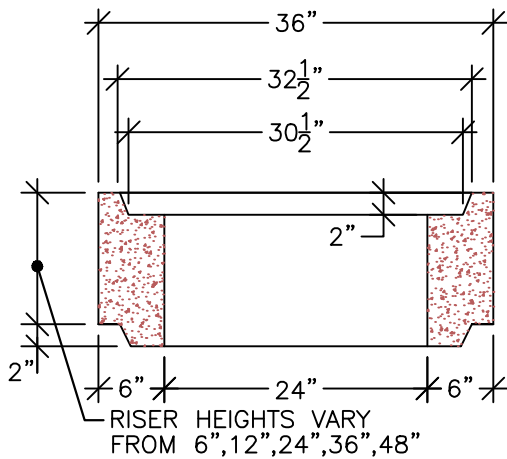

RISER (OPTIONAL)

SPECIFICATIONS:

MEETS OR EXCEEDS 5000 PSI CONCRETE
(MEETS ASTM 890)

AIR ENTRAINMENT 6%

STEEL MEETS ASTM A615 GRADE 60

H-20 LOADING

WEIGHT:

• 1773 LBS. [.9 TON]

• RISER—PER FOOT OF RISE: 740 LBS. [.37 TON]

GALLONS:

• 2.49 GALS PER INCH OF RISE

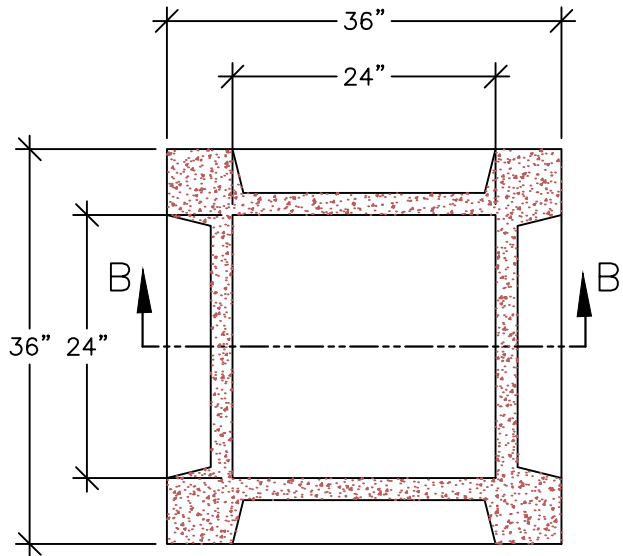

SECTION A-A

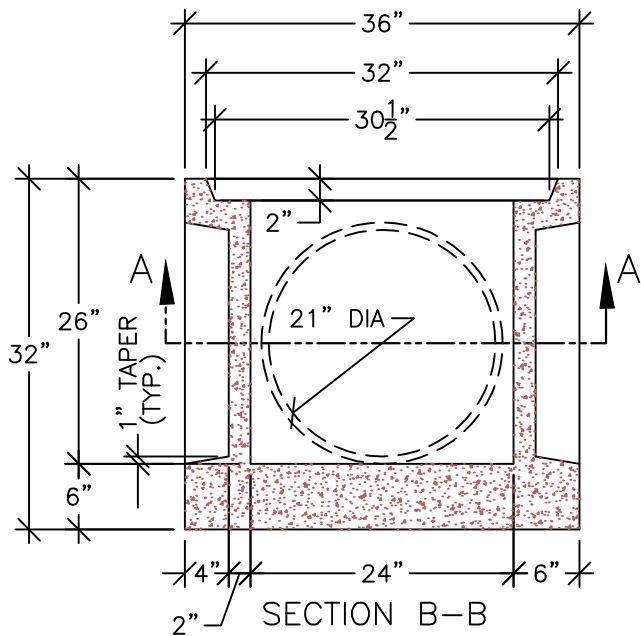

SECTION B-B

CATCH BASIN - 24" X 24"x24" w/KNOCKOUTS

DRAWN BY: LWK

FILE NAME:
CB-24X24wKO

DATE:
7/18/03

SCALE:
3/4= 1' 0"

SHEET:
CB-3